

# PS100E01 series 0.5-4.5V ceramic pressure sensors

## Features

- Thermally compensated
- High accuracy and high stability
- Wide choice of measuring ranges
- Solid ceramic sensitive diaphragm
- Smart volume, easy for encapsulation
- Excellent shock and vibration resistance
- Excellent corrosion and abrasion resistance
- Low cost, extreme extensive application range



## Descriptions

PS100E01 series 0.5-4.5V ceramic pressure sensor is made with ceramic cell (Al<sub>2</sub>O<sub>3</sub> 96%) and works following the piezoresistive principle, the signal conditioning is done by a small PCB, which is mounted directly to the sensor, offers 0.5-4.5V, 0.2-4.5V ratio-metric voltage signal (customized is available). Electronics provides offset and span correction when the temperature changes, therefore an excellent long-term stability and negligible temperature drifts can be guaranteed, it has been developed for low cost applications, e.g. automotive applications.

PS100E01 series has the reinforced outer area (monolithic structure), the sensor is easy to mount in a plastic or metallic case by using O-ring, and thanks to the good chemical resistance of the ceramic, the sensor can measure pressure in nearly all aggressive media.

## Mounting recommendations

The sensor is sensitive to the humidity, here is some recommendations for mounting. Before mounting, put the sensor into a drying oven with 85°C for at least 30 minutes. During mounting, make sure the environment humidity is keep under 50%. After mounting, appropriate sealing measures should be taken to protect the sensor.

## Technical data

Performance (EN 60770)

Power supply	5 VDC (ratio-metric)	<a href="#">See more in page 2 (part number chart)</a>
Output signal	0.5 to 4.5 V	<a href="#">See more in page 2 (part number chart)</a>
Pressure range	0...1 bar to 400 bar	
Temperature characteristic	± 0.02% F.S./°C (25 → 85 °C)	
Operating temperature	0 → 85 °C	
Stability	< 0.2% F.S.O./year	
Material	Ceramic Al <sub>2</sub> O <sub>3</sub> 96%	
Sensor type	Gauge	
Technology	Piezoresistive	
Weight	8 g	

# PS100E01 series 0.5-4.5V ceramic pressure sensors

Typical pressure and accuracy (Unit: bar)

Rated range	2	5	10	20	30	50	100	200	400
Over pressure	4	10	20	40	60	100	200	400	600
Burst pressure	7	15	35	70	90	150	250	450	600
Accuracy @ 25° C	±1.5%F.S.		±1.0%F.S.				±1.5%F.S.		

Dimensions (Unit: mm)

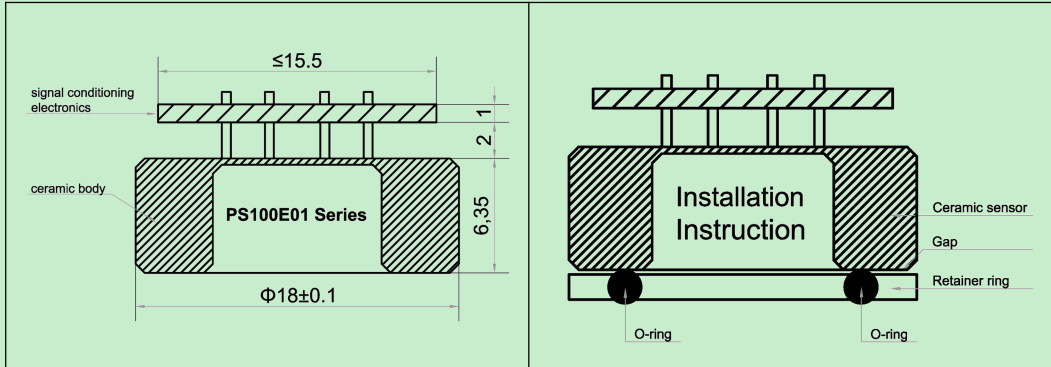

Electrical connections

	Pins	Wires	Function
	V+	Red	Voltage +
	V-	Black	GND
	Vo	Blue	Signal +

## Part number chart (How to order)

PART NUMBER REQUIRED: **PS100E01.D.01.A.02 (EXAMPLE)**

1	Pressure range(bar) A(1) B(2) C(5) D(10) E(20) F(30) G(50) H(100) I(200) J(250) K(400) 1Z(Other pressure range or unit is on request)	<b>D</b>
2	Output signal 01(0.2-4.5V) 02(0.5-4.5V) 03(0.2-3.0V) 04(0.5-3.0V) 05(0.2-3.8V) 2Z(Other output is on request)	<b>01</b>
3	Power supply A(5VDC ratio-metric) B(9-15VDC) C(3-3VDC) 3Z(Other supply is on request)	<b>A</b>
4	Electrical connection 01(3Pins*7mm) 02(3Wires*50mm)	<b>02</b>

## PS100E01 series 0.5-4.5V ceramic pressure sensors

### Contact us

Company	Ningbo Sendo Electronic Technology CO., LTD	
Email	sales@sendo-sensor.com	
Email	cain.chen@sendo-sensor.com	
Factory	No 15, Yongxing 2nd Rd, Chengbei Industrial Park, Huizhou District, 245900 China	
Office	Building. 1#1108, Wante business center, Hi-Tech, 315040 China	
Website	<a href="http://www.pressuresensorsuppliers.com">http://www.pressuresensorsuppliers.com</a>	<a href="http://www.sendo-sensor.com">http://www.sendo-sensor.com</a>
Skype: sendosensor	WeChat: chenjie4884	WhatsApp: +8613616574884
Tel: 0086-0574-27725960	Fax: 0086-0574-27725970	Phone: 0086-13616574884

\*Specifications subject to change without notice, the latest date sheet please contact: sales@sendo-sensor.com